



NEWTOP[®]
ONE STOP . POWERED OUTDOORS

NEWTOP[®]
ONE STOP . POWERED OUTDOORS

ADD:9/F B3, No.1599 Xinjinqiao Road, IBC
(International Business Center) ,Pudong Shanghai,China.
Email:service@newtop.com.cn

<https://newtopools.com>

9.8HP 9.9HP 15HP 30HP 40HP 60HP

**HIGH-PERFORMANCE
OUTBOARD MOTOR**

<https://newtopools.com>

HIGH-PERFORMANCE OUTBOARD MOTOR

Widely used across fishing operations, commercial cruising and recreational boating, NEWTOP outboard motors are designed as reliable power solutions for a broad range of marine applications. With an integrated structure and installation-friendly design, they deliver dependable performance for both professional and every day on-water use.



OUTBOARD MOTOR INDEX

ADVANCED TECHNOLOGY 01-02

T3 T5 04
OUTBOARD MOTOR

T8 T9.8 05
OUTBOARD MOTOR

T9.9 T15-63V 06
OUTBOARD MOTOR

T15-6B4 T18 07
OUTBOARD MOTOR

T25 T30 08
OUTBOARD MOTOR

T40X T40G/40J T60 10
OUTBOARD MOTOR

F6 F20 11
OUTBOARD MOTOR

F60B 12
OUTBOARD MOTOR



ADVANCED TECHNOLOGY

ULTIMATE USER EXPERIENCE



Five-Layer Anti-Corrosion: Ultimate Protection

Employs an industry-leading "five-layer anti-corrosion treatment process."
 Dual Chemical Barrier: First, an oxidation treatment generates a white aluminum oxide film on the aluminum alloy surface; subsequently, a specialized reaction process forms a dense, protective anti-corrosion film.
 Triple Physical Coating: Building upon the dual chemical barrier, critical underwater components undergo three distinct layers of anti-corrosion paint application.
 Result: Creates an impenetrable "iron wall" for aluminum alloy components—providing internal resistance against permeation and external resistance against corrosion—thereby significantly extending their service life.



Meticulously Selected Materials: No Expense Spared

Main Body Materials: All core components are crafted from an original Japanese-formula aluminum alloy, balancing exceptional strength with superior casting properties.
 Upgraded Critical Load-Bearing Components: Key structural points—such as the rotating bracket, bracket shaft, and left/right clamping brackets—are specifically upgraded using reinforced, high-strength aluminum alloy.
 Both the main body and critical load-bearing components exhibit excellent toughness and enhanced corrosion resistance, ensuring structural integrity and safety even under extreme operating conditions.



Oven Annealing: Eliminating Internal Stress

All core aluminum alloy components (including the engine block, gearbox housing, intermediate housing, bottom cover, etc.) undergo a rigorous oven-based annealing and heat-retention process.
 Process Objective: To effectively eliminate metallurgical defects—such as inclusions, grain boundary issues, twinning, and dislocations—within the material structure, thereby releasing internal stress.
 Performance Enhancement: Significantly boosts the strength, toughness, and durability of the components, completely eliminating the risk of structural deformation.



Precision Manufacturing: CNC Machining

All core components (including cylinder head covers, sealing caps, etc.) are finished using high-precision CNC machining centers across the entire production line.
 Ensures micron-level machining accuracy, achieving a perfect fit between components and enhancing the overall operational smoothness of the entire unit.



Imported Bearings: Powerful Core Dynamics

All internal core transmission assemblies come standard with genuine, original-import Japanese bearings. These bearings deliver superior high-speed rotational performance, exceptional stability, and an ultra-long service life, resulting in smoother power output.



OEM-Grade Quality: A Legacy of Excellence

Muffler Cover: Constructed from the exact same Fiberglass Reinforced Plastic (FRP) material used in original equipment, offering excellent sound insulation and superior weather resistance.
 Drive Gear Set: The specifications for the pinion, forward, and reverse gears are an exact match to the original components, ensuring smooth engagement, high transmission efficiency, and a rapid boost in top speed.
 Fasteners: Features heavy-duty figure-8 iron-chromium alloy bolts; the surfaces undergo hexavalent chromium passivation treatment to provide exceptional corrosion resistance.



Fluid Dynamics Optimization: Energy Efficiency and Speed Enhancement

The propeller utilizes a high-precision powder-coating process, resulting in a durable finish and an exceptionally smooth surface profile.
 Result: During underwater operation, the design improves cavitation envelope characteristics and reduces hydrodynamic drag, delivering the dual benefits of faster cruising speeds and lower fuel consumption.



Meticulous Detail: Robust and Durable

The propeller thrust washer is specially crafted from 304 stainless steel, offering superior resistance to seawater corrosion to ensure long-lasting, secure fastening—providing complete peace of mind.

HIGH-PERFORMANCE OUTBOARD MOTOR

Widely used across fishing operations, commercial cruising and recreational boating, NEWTOP outboard motors are designed as reliable power solutions for a broad range of marine applications. With an integrated structure and installation-friendly design, they deliver dependable performance for both professional and every day on-water use.



T3



T5

- 📦 PORTABLE ⚙️ EFFICIENT
- 📏 COMPACT ⚖️ LIGHTWEIGHT
- 🔧 EASY TO MAINTAIN

Model	T3	T5
Max. Output Power	3.0hp/2.2kW	5.0hp/3.7kW
Tansom Height	15"	15"
Engine Type	L1	L1
Displacement	70cc	103cc
Bore X Stroke	46X42mm	54X45mm
Ignition System	CDI	CDI
Max.RPM Range	4500-5500rpm	4500-5500rpm
Idling RPM Range	1000-1100rpm	1000-1100rpm
Fuel Induction System	Carburetor	Carburetor
Steering System	Tiller	Tiller
Starting System	Manual	Manual
Gear Shift	F-N-R	F-N-R
Gear Ratio	2.08	2.08
Trim and Tilt	Manual	Manual
Fuel Tank Capacity	Built-in 1.4L	Built-in 2.8L/12L Outside
Max. Fuel Consumption	1.5L/h	2.6L/h
Lubrication System	50:1	50:1
Gear Oil Capacity	100cc	195cc
Rectifier Charging Capacity	None	None
Propeller Options	7-1/4"X5-1/2"-BL	7-1/2"X7"-BL
N.W./G.W.	17kgs	20/21kgs

Widely used across fishing operations, commercial cruising and recreational boating, NEWTOP outboard motors are designed as reliable power solutions for a broad range of marine applications. With an integrated structure and installation-friendly design, they deliver dependable performance for both professional and everyday on-water use.

Widely used across fishing operations, commercial cruising and recreational boating, NEWTOP outboard motors are designed as reliable power solutions for a broad range of marine applications. With an integrated structure and installation-friendly design, they deliver dependable performance for both professional and everyday on-water use.



T8

Model	T8	T9.8
Max. Output Power	8.0hp/5.9kW	9.8hp/7.2kW
Tansom Height	15/20"	15/20"
Engine Type	L2	L2
Displacement	169cc	169cc
Bore X Stroke	50X43mm	50X43.1mm
Ignition System	CDI	CDI
Max. RPM Range	4500-5500rpm	5000-6000rpm
Idling RPM Range	1150-1250rpm	1150-1250rpm
Fuel Induction System	Carburetor	Carburetor
Steering System	Tiller	Tiller
Starting System	Manual	Manual
Gear Shift	F-N-R	F-N-R
Gear Ratio	2.08	2.08
Trim and Tilt	Manual	Manual
Fuel Tank Capacity	12L	12L
Max. Fuel Consumption	4.3L/h	5.1L/h
Lubrication System	50:1	50:1
Gear Oil Capacity	320cc	320cc
Rectifier Charging Capacity	None	None
Propeller Options	3-8.3"	3-8.3"
N. W./G. W.	26/27kgs	26/27kgs



T9.8

- FAST ACCELERATION
- HIGH EFFICIENCY
- PORTABLE
- LIGHTWEIGHT
- EASY TO MAINTAIN
- COMPACT
- FUEL-EFFICIENT



T9.9

- FAST ACCELERATION
- HIGH EFFICIENCY
- PORTABLE
- LIGHTWEIGHT
- EASY TO MAINTAIN
- COMPACT
- FUEL-EFFICIENT



T15-63V

Model	T9.9	T15-63V
Max. Output Power	9.9hp/7.3kW	15hp/11kW
Tansom Height	15/20"	15/20"
Engine Type	L2	L2
Displacement	246cc	246cc
Bore X Stroke	56X50mm	56X50mm
Ignition System	CDI	CDI
Max. RPM Range	4500-5500rpm	4500-5500rpm
Idling RPM Range	950-1050rpm	950-1050rpm
Fuel Induction System	Carburetor	Carburetor
Steering System	Tiller	Tiller
Starting System	Manual	Manual
Gear Shift	F-N-R	F-N-R
Gear Ratio	2.08	2.08
Trim and Tilt	Manual	Manual
Fuel Tank Capacity	24L	24L
Max. Fuel Consumption	5.1L/h	7.9L/h
Lubrication System	50:1	50:1
Gear Oil Capacity	250cc	250cc
Rectifier Charging Capacity	None	None
Propeller Options	3-8"/10"/11"/12"	3-8"/10"/11"/12"
N. W./G. W.	36/37.5kgs	36/37.5kgs

Widely used across fishing operations, commercial cruising and recreational boating, NEWTOP outboard motors are designed as reliable power solutions for a broad range of marine applications. With an integrated structure and installation-friendly design, they deliver dependable performance for both professional and everyday on-water use.

Widely used across fishing operations, commercial cruising and recreational boating, NEWTOP outboard motors are designed as reliable power solutions for a broad range of marine applications. With an integrated structure and installation-friendly design, they deliver dependable performance for both professional and everyday on-water use.



T15-6B4

Model	T15-6B4	T18
Max. Output Power	15hp/11kW	13.2kW/18hp
Tansom Height	15/20"	15/20"/25"
Engine Type	L2	L2
Displacement	246cc	294cc
Bore X Stroke	56X50mm	60X52mm
Ignition System	CDI	CDI
Max.RPM Range	4500-5500rpm	5200-5800rpm
Idling RPM Range	950-1050rpm	800-950rpm
Fuel Induction System	Carburetor	Carburetor
Steering System	Tiller	Tiller Handle
Starting System	Manual	Manual
Gear Shift	F-N-R	F-N-R
Gear Ratio	2.08	13:24
Trim and Tilt	Manual	Manual
Fuel Tank Capacity	24L	25L
Max. Fuel Consumption	7.9L/h	8.3L/h
Lubrication System	50:1	50:1
Gear Oil Capacity	250cc	370ml
Rectifier Charging Capacity	None	N/A
Propeller Options	3-8"/10"/11"/12"	6" - 11.5"
N. W. /G. W.	36/37.5kgs	41kgs



T18

- POWERFUL
- PORTABLE
- LIGHTWEIGHT
- EASY TO MAINTAIN
- FAST ACCELERATION
- EFFICIENT
- FUEL-SAVING



T25

- POWERFUL
- EFFICIENT
- EASY TO MAINTAIN
- COMFORTABLE
- FAST ACCELERATION
- LIGHTWEIGHT
- FUEL-SAVING



T30

Model	T25	T30
Max. Output Power	25hp/18kW	30hp/22kW
Tansom Height	15/20"	15/20"
Engine Type	L2	L2
Displacement	496cc	496cc
Bore X Stroke	72X61mm	72X61mm
Ignition System	CDI	CDI
Max.RPM Range	4500-5500rpm	4500-5500rpm
Idling RPM Range	1050-1150rpm	1050-1150rpm
Fuel Induction System	Carburetor	Carburetor
Steering System	Tiller/Remote	Tiller/Remote
Starting System	Manual or Electric	Manual or Electric
Gear Shift	F-N-R	F-N-R
Gear Ratio	2.08	2.08
Trim and Tilt	Manual	Manual
Fuel Tank Capacity	24L	24L
Max. Fuel Consumption	12L/h	12L/h
Lubrication System	50:1	50:1
Gear Oil Capacity	320cc	320cc
Rectifier Charging Capacity	12V,7A	12V,7A
Propeller Options	3-11"/12"	3-11"/12"
N. W. /G. W.	52/57.5kgs	52/57.5kgs

Widely used across fishing operations, commercial cruising and recreational boating, NEWTOP outboard motors are designed as reliable power solutions for a broad range of marine applications. With an integrated structure and installation-friendly design, they deliver dependable performance for both professional and every day on-water use.



T40X

T40G / 40J

T60

- POWERFUL
- LARGE DISPLACEMENT
- LIGHTWEIGHT
- EASY TO MAINTAIN
- FAST ACCELERATION
- EFFICIENT
- FUEL-SAVING
- HIGH DURABILITY

Model	T40X	T40G/40J	T60
Max. Output Power	40hp/29.4kW	40hp/29.4kW	60hp/44.1kW
Tansom Height	15/20"	15/20"	20/22"
Engine Type	L2	L2	L3
Displacement	703cc	669cc	849cc
Bore X Stroke	80X70mm	78X70mm	72X69.5mm
Ignition System	CDI	CDI	CDI
Max. RPM Range	4500-5500rpm	4500-5500rpm	4500-5500rpm
Idling RPM Range	950-1050rpm	1100-1200rpm	950-1050rpm
Fuel Induction System	Carburetor	Carburetor	Carburetor
Steering System	Tiller/Remote	Tiller/Remote	Tiller/Remote
Starting System	Manual or Electric	Manual or Electric	Manual or Electric
Gear Shift	F-N-R	F-N-R	F-N-R
Gear Ratio	2	2	2.33
Trim and Tilt	Manual/Electric	Manual	Hydraulic/Electric
Fuel Tank Capacity	24L	24L	24L
Max. Fuel Consumption	20L/h	20L/h	25.5L/h
Lubrication System	50:1	50:1	50:1
Gear Oil Capacity	430cc	315cc	610cc
Rectifier Charging Capacity	12V,7A	12V,7A	12V,7A
Propeller Options	3-12"/13"	3-12"/13"	3-13"/15"/17"
N. W. /G. W.	73.5/81.7kgs	65/68.5kgs	102 /107kgs



Widely used across fishing operations, commercial cruising and recreational boating, NEWTOP outboard motors are designed as reliable power solutions for a broad range of marine applications. With an integrated structure and installation-friendly design, they deliver dependable performance for both professional and every day on-water use.

Widely used across fishing operations, commercial cruising and recreational boating, NEWTOP outboard motors are designed as reliable power solutions for a broad range of marine applications. With an integrated structure and installation-friendly design, they deliver dependable performance for both professional and every day on-water use.



F6

Model	F6	F20
Max. Output Power	6hp/4.4kw	20hp/14.7kW
Stroke	4-Stroke	4-Stroke
Tansom Height	15"(S)/20"(L)	15/20"
Engine Type	Single, OHV	L2 SOHC
Displacement	139cc	362cc
Bore X Stroke	62X46mm	63X58.1mm
Ignition System	CDI	CDI
Max. RPM Range	4500-5500rpm	5000-6000rpm
Idling RPM Range	1050-1150rpm	1000-1100rpm
Fuel Induction System	Carburetor	Carburetor
Steering System	Tiller	Tiller
Starting System	Manual	Manual or Electric
Gear Shift	F-N-R	F-N-R
Gear Ratio	2.08(27:13)	1.85
Trim and Tilt	Manual	Manual
Fuel Tank Capacity	Built-in 1.1L	24L
Max. Fuel Consumption	2.3L/h	6.9L/h
Engine Oil Capacity	0.6L	1.6L
Gear Oil Capacity	195ml	250ml
Rectifier Charging Capacity	12V,7A	12V,7A
Propeller Options	3-7-1/2X8-BA"	3-8"
N. W. /G. W.	S:27kgs/35kgs; L:28kgs/36kgs	51.7/56kgs



F20

- PORTABLE
- LIGHTWEIGHT
- EASY TO MAINTAIN
- FUEL-EFFICIENT
- EFFICIENT
- COMPACT
- COMFORTABLE
- FUEL-SAVING



F60B

Model	F60B
Max. Output Power	60hp/44.1kW
Stroke	4-Stroke
Tansom Height	20"
Engine Type	L4 SOHC
Displacement	996cc
Bore X Stroke	65X75mm
Ignition System	CDI
Max. RPM Range	5000-6000rpm
Idling RPM Range	850-950rpm
Fuel Induction System	EFI
Steering System	Remote
Starting System	Electric
Gear Shift	F-N-R
Gear Ratio	2
Trim and Tilt	Electric
Fuel Tank Capacity	24L
Max. Fuel Consumption	20L/h
Engine Oil Capacity	2.5L
Gear Oil Capacity	430ml
Rectifier Charging Capacity	12V,25A
Propeller Options	3-12"/13"
N. W. /G. W.	162/118.7kgs

- POWERFUL
- FAST ACCELERATION
- LARGE DISPLACEMENT
- HIGH EFFICIENCY
- COMFORTABLE
- FUEL-EFFICIENT
- VERSATILITY



ACCESSORY RANGE
INDEX

EXPERT
ACCESSORY RANGE

**THE BEST YOUR
TOOL CAN GET.**

Our new top performance range for all trades
Longer, tougher, faster: Up to 100x better
performanceAdvanced technologies for the
toughest applications

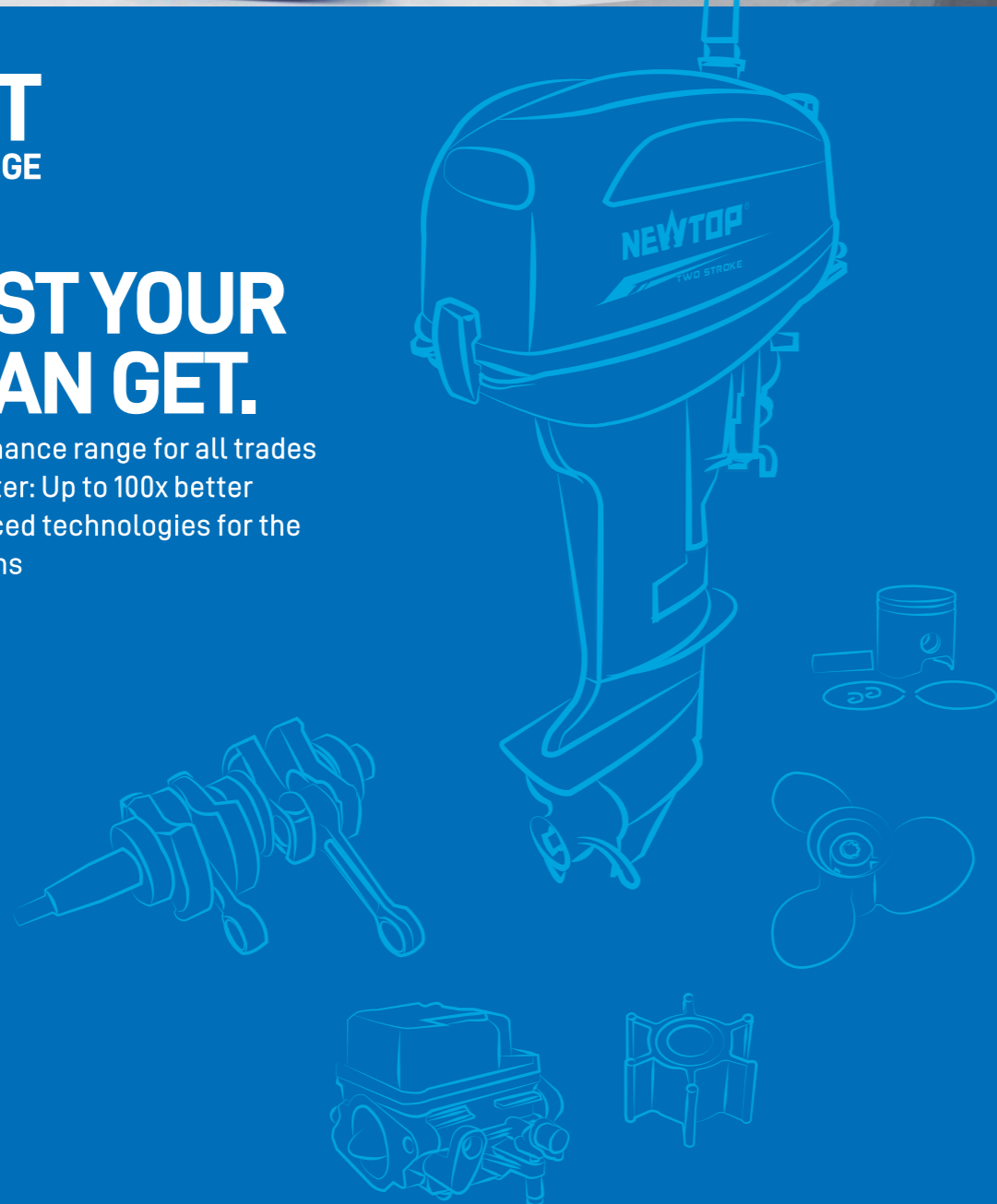

T8/T9.8 15-18
OUTBOARD SPARE PARTS

T9.9/T15-63V 19-22
OUTBOARD SPARE PARTS

T15-6B4 23-28
OUTBOARD SPARE PARTS

T25/T30 29-32
OUTBOARD SPARE PARTS

T40X 33-36
OUTBOARD SPARE PARTS

T40J/T40G 37-40
OUTBOARD SPARE PARTS

PROPELLER ASSY 41-44

T8/T9.8
OUTBOARD
SPARE PARTS

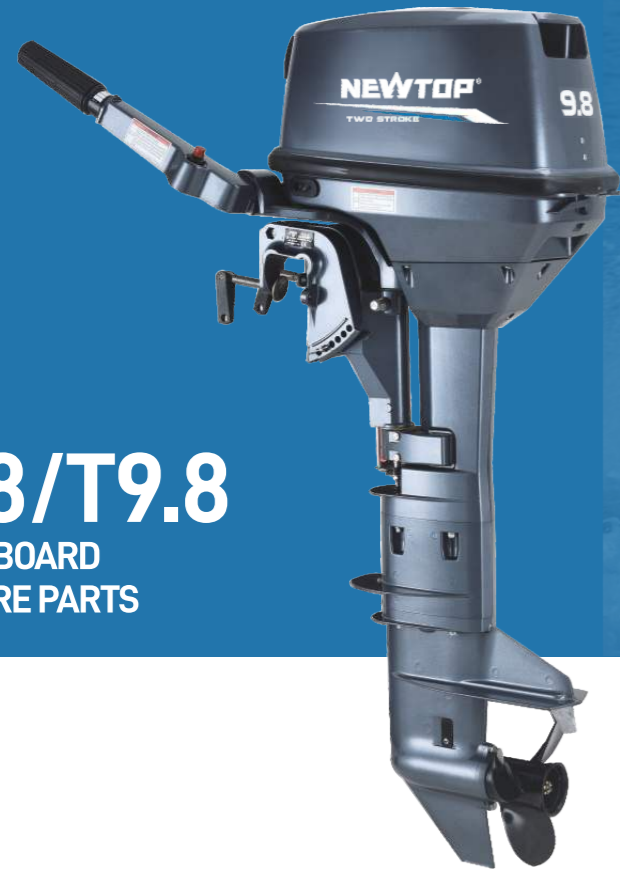

Side of a mount rubber lower
3B2-61302-0



Reverse lock shaft
3B2-66321-1



Mount barcket L
3B2S61401-0



Mount barcket R
3B2S61402-1



Steering shaft
3B2S62010-0

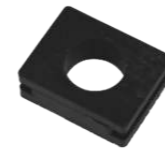

Water pipe upper grommet
3B2-65195-0



Exhaust pipe
3B2-02311-0

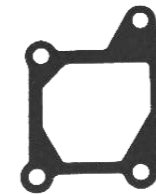

Exhaust pipe gasket
3B2-02312-0



Choke rod
3B2-67151-0



Bottom cowling
3B2S67100-1



Swivel bracket
3B2S62310-0



Clamp handle rivet
3C8-62104-0



Clamp handle
307S62102-0



Clamp screw pad
332-62101-0



Clamp screw
369-62103-0



Shift lever spring plate
3C8-66116-0



Starter lock lever
3B2-05211-1



Throttle drum holder
3B2-63506-0



Throttle drum
3B2-63611-0



Advancer lever &
Rod snap 3B2-63711-0
345-05224-0



Stern bracket R
369S62112-3



Stern bracket L
369S62113-2



Steering handle
3B2S63011-1



Lanyard stop switch &
lock 398-06830-0
353-06821-0

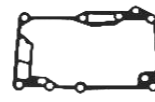

Upper casing gasket
3B2-61012-0



Throttle control link rod
3B2-63716-0



Throttle arm
3B2-63751-0



Shift lever
3B2-66110-0



















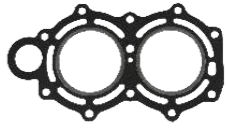
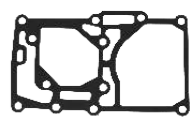

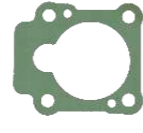
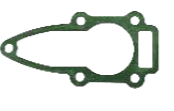

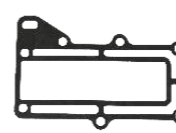



































Shift rod lever
3B2-66225-0



Pinion gear needle bearing
3B2-60211-0































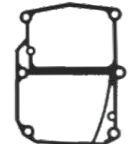

									
Pinion gear 3B2-64020-0	Forward gear & Reverse gear 3B2-64020-0 3B2-64030-0	Clutch spring 3B2-64221-0	Propeller thrust holder 3B2-64230-0	Pump case liner 3B2-65011-0	Oil seal set 3B2-01215-0	Oil seal set 101-00121-00 3B2-001220	Piston needle bearing 338-00042-0	Cylinder head gasket 3B2-01005-0	Engine base gasket 3B2-01303-0
									
Pump case upper 3B2-65016-0	Pump case lower 3B2-65017-0	Outer Plate gasket 3B2-65018-0	Plunger shift 3B2-65020-0	Impeller 3B2-65021-1	Outer exhaust cover 3B2B02300-0	Exhaust cover gasket 3K9-02305-0	Cylinder head 3K9B01001-0	Crankcase 3K9B01100-1	Exhaust inner cover 3K9-B02302-0
									
Outer plate 3B2-65025-0	Outer plate gasket lower 3B2-65029-0	Propeller 3B2B64515-1	Lower pump case oil seal 309-60111-0	Water pipe lower grommet 331-65014-0	Carburetor 3K9-03200-0	Fuel filter comp 369-02230-0	Fuel line comp 3B7-70200-3	Water inlet	Crankshaft 3B2-00030-0
									
Bearing housing o-ring 345-65015-0	Propeller nut 369-64121-0	Propeller washer 369-64124-0	Housing ball bearing 9601-0-6004	Split pin 951503-0318	Crankcase head gasket 3B2-01214-0	Starter lock rod 3B2-05217-1	Barcket distance plate 3B2-62118-0	Throttle cabl 3B2-63600-1e	Propeller shaft&clutch 3B2-64211-0
									
Flywheel 3B2-06101-0	Stator coil base 3B2-06102-1	Exciter coil 3B2-06120-0	C.D.I unit 3B2-06170-0	Lower set plate 3B2-63724-0	Drive shaft L 3B2-64302-0	Water pipe L 3B2-65110-0	Shift cam shaft assy L 3B2-66013-0	Fuel tank assy(12L) 3B2-70167-0	Lower casing 3B2S60000-0
									
Coil plate stopper 3K9-05233-0	Air silencer 3B2-02411-0	Intake manifold 3B2B02010-0	Carburetor gasket 369-02011-0	Piston assy 3B2-00011-0	Shift lever stopper 3C8-66112-0	Top cowling assy 3K9S67500-1	Trim tab anode 3V1-60217-0	Ball joint B 346-05228-0	Clutch ring































































**T9.9
T15-63V**
OUTBOARD SPARE PARTS



				
Transom clamp handle 6E0-43118-01	Clamp bracket 63V-43111-07-8D 63V-43112-08-8D	Tilt stop lever 63V-43181-00	Swivel bracket 63V-43311-03-8D	Clamp bracket bolt 63W-43131-01
				
Receiver assy 66M-43350-01	Tilt lock plate 66R-43615-00	Transom clamp pad 648-43114-01	Tilt rod assy 689-43160-00	Bolt 90101-06M29
				
Tilt stop bolt 90109-06M84	Transom clamp thumb screw 90149-14030	Self-locking nut 90185-22043	Pin 90243-04M01	Bushing 90386-22M94

				
Collar 90387-06M13	Torsion spring 90508-18M41	Circlip 99080-05600	Steering bracket 63V-42511-04-8D	Upper side mount damper 63V-44514-01-CA
				
Lower mount rubber housing 63V-44551-01-4D	Lower front mount damper 63V-44557-00	Pivot shaft Bushing 65F-42537-00	Bush 90386-30048	Bolt&Nut 97095-06555 95380-06700
				
Bolt&Nut 97095-06555 95380-06700	Throttle cable assy 6L2-26301-00	Gear shift handle 63V-44111-02	Engine stop switch assy 65W-82575-01	Stopper 682-82556-00
				
Collar 90387-06M86	Exhaust manifold gasket 63V-41133-A1	Exhaust manifold seal 63V-41135-00	Upper casing 63V-45113-A1	EXT,1 manifold 65F-41131-00-CA
				
Clamp hook 6E7-42816-00	Clamp lever 63V-42815-01-8D	Starter stop cable comp 63V-15770-01	Shift of rod upper 63V-44143-01	Shift cam assy L 63V-44150-10
				
Water pump of housing upper 6B4-44121-00	Cartridge insert 63V-44322-00	Cartridge outer plate 63V-44323-00	Impeller 63V-44352-01	Lower casing 63V-45311-01-8D



									
Lower casing packing 63V-45315-A0	Pump of housing lower 63V-45331-00-CA	Drive shaft assy L 63V-45510-11	Pinion gear 63V-45551-00	Forward gear&Reverse gear 6E7-45560-01 6E7-45571-00	Reed valve assy 63V-13610-10	Intake silencer assy 63V-14440-A0	Choke rod 63V-41257-00	Thermostat 6E5-12411-02	Cylinder head 6E7-11111-01-1S
									
Water seal of damper 647-44366-00	Cross pin ring 648-45633-00	Plunger Shift 650-45635-00	Clutch dog 682-45631-00	Propeller shaft 683-45611-00	Cylinder head gasket 63V-11181-A1	Crankcase 63V-15100-02	Exhaust inner cover 63V-41111-00-1S	Exhaust inner cover gasket 63V-41112-A0	Exhaust outer cover 63V-41113-00-1S
									
Straight pin 90250-05010	Compression spring 90501-14M06	Pump base oil seal& Propeller shaft oil seal 93101-20001 93101-17001	Pump O-ring 93210-44398	Gear II bearing 93306-00501	Engine anode 682-11325-00	Thermostat cover 682-12413-00-1S	Thermostat cover gasket 682-12414-A1	Spark plug 94702-00160	Piston assy 6E7-11631-00-97
									
Pinion gear needle bearing 93315-314V8	Propeller shaft needle bearing 93315-317U2	GEAR I bearing 93332-00005	Pinion bearing 93341-41414 6E8-45587-10	Spacer 6E7-45987-01	Crankshaft assy 63V-11400-00	Oil seal housing 63V-15396-01-CA	Housing oil seal 93101-13M27	Crankshaft lower oil seal 93101-25018	Crankshaft upper oil seal 93110-23M00
									
Water inlet 1&2 cover 6G1-45214-00 63V-45215-00	Lower casing anode 61N-45251-01	Water tube 1 L 63V-44361-11	Castle nut 90171-10M01	Plate washer 90201-10M01	Piston needle bearing 93602-14104	Fuel pipe joint comp.1 6G1-24304-02	Fuel lter assy 61N-24560-00	C.D.I unti assy 63V-85540-01	Ignition coil assy 63V-85570-00
									
Cotter pin 91490-30020	Magneto base retainer 63V-41611-00	Charging coil 63V-85520-01	Rotor assy 63V-85550-11	Pulser coil 63V-85580-01	Starter assy 63V-15710-20	Top cowling assy 63V-42610-00	Carburetor 63V-14301-00	Propeller 3-9.25X11J	Steering handle assy 63V-42111-01-4D (63V-W0084-00)

T15-6B4 OUTBOARD SPARE PARTS



Top cowling
6B4-42610-20



Crank cylinder assy
6B4-15100-00-1S



Anode
6B4-45251-00



Exhaust inner cover
63V-41111-00-1S



Exhaust inner cover
gasket
6B4-41112-A0



Thermostat
6E5-12411-30



Crankshaft Oil Seal
93102-25010
93110-23M00



Crankshaft Assy
6B4-11400-00



Piston Assy
6E7-11631-00-97



Reed valve assy
63V-13610-10



Exhaust outer cover
63V-41113-00-1S



Head cylinder
6B4-11111-00-1S



Cylinder head gasket
63V-11181-A2



Cylinder head cover
6B4-11191-00-1S



Head cover gasket
6B4-11193-A1



Intake silencer assy
6B4-14440-00



Carburetor
6B3-14301-00



Fuel Filter
61N-24560-00



6B4-15710-0010
Maunal starter assy



Rotor assy
6B4-85550-01



Thermostat cover
682-12413-00-1S



Cover gasket
682-12414-A1



Spark plug
94702-00160



Oil seal housing
6B4-15396-00-CA



O-ring
93210-46M16



Pulser coil
6B4-85550-00



Charge coil
6B4-85520-00



Lighting coil
63V-85533-00



CDI unit assy
6B4-85540-03



Ignition coil assy
6B4-85570-00









				
Lower casing packing 63V-45315-A0	Pump of housing lower 63V-45331-00-CA	Drive shaft assy L 63V-45510-11	Pinion gear 63V-45551-00	Forward gear&Reverse gear 6E7-45560-01 6E7-45571-00

				
Reed valve assy 63V-13610-10	Intake silencer assy 63V-14440-A0	Choke rod 63V-41257-00	Thermostat 6E5-12411-02	Cylinder head 6E7-11111-01-1S

				
Water seal of damper 647-44366-00	Cross pin ring 648-45633-00	Plunger Shift 650-45635-00	Clutch dog 682-45631-00	Propeller shaft 683-45611-00





				
Cylinder head gasket 63V-11181-A1	Crankcase 63V-15100-02	Exhaust inner cover 63V-41111-00-1S	Exhaust inner cover gasket 63V-41112-A0	Exhaust outer cover 63V-41113-00-1S

				
Straight pin 90250-05010	Compression spring 90501-14M06	Pump base oil seal& Propeller shaft oil seal 93101-20001 93101-17001	Pump O-ring 93210-44398	Gear II bearing 93306-00501

				
Engine anode 682-11325-00	Thermostat cover 682-12413-00-1S	Thermostat cover gasket 682-12414-A1	Spark plug 94702-00160	Piston assy 6E7-11631-00-97

				
Pinion gear needle bearing 93315-314V8	Propeller shaft needle bearing 93315-317U2	GEAR I bearing 93332-00005	Pinion bearing 93341-41414 6E8-45587-10	Spacer 6E7-45987-01

				
Crankshaft assy 63V-11400-00	Oil seal housing 63V-15396-01-CA	Housing oil seal 93101-13M27	Crankshaft lower oil seal 93101-25018	Crankshaft upper oil seal 93110-23M00

				
Water inlet 1&2 cover 6G1-45214-00 63V-45215-00	Lower casing anode 61N-45251-01	Water tube 1 L 63V-44361-11	Castle nut 90171-10M01	Plate washer 90201-10M01

				
Piston needle bearing 93602-14104	Fuel pipe joint comp.1 6G1-24304-02	Fuel lter assy 61N-24560-00	C.D.I unti assy 63V-85540-01	Ignition coil assy 63V-85570-00

				
Cotter pin 91490-30020	Magneto base retainer 63V-41611-00	Charging coil 63V-85520-01	Rotor assy 63V-85550-11	Pulser coil 63V-85580-01

				
Starter assy 63V-15710-20	Top cowling assy 63V-42610-00	Carburetor 63V-14301-00	Propeller 3-9.25X11J	Steering handle assy 63V-42111-01-4D (63V-W0084-00)



Cowling bottom rubber seal 6B4-42716-00	Engine stop switch assy 6E9-82575-02	Stopper 682-82556-00	Handle steering assy 6B4-42111-00-4D	Rubber handle 6G1-42177-00
Handle steering 6B4-42111-00-4D	Handle steering cover 6B4-42131-00-4D	Throttle lever 6B4-42136-00	Throttle cable assy 6B4-26301-00	Throttle wire stay 63V-14497-02
Gear shift handle 6B4-44111-00-4D	Shift rod lever 6B4-44121-00	Shift rod cam 6B4-44125-00	Shift bracket 6B4-41662-00	Arm 6B4-15746-00
Link rod 6L2-15747-00	Starter stop cable Comp 6B4-15770-00	Tilt rod assy 689-43160-00	Swivel bracket 682-43311-07-4D	Shallow water drive lever 6B4-43681-00
Steering bracket 6B4-42511-00-4D	Steering pivot 682-42521-00-94	Upper side mount damper 682-44514-01-94	Bracket clamp 682-43112-05-4D 682-43111-05-4D	Lower mount rubber housing 682-44551-02-4D 682-44552-02-5D
Exhaust guide 6B4-41137-00-CA	Upper casing gasket 682-45113-A2	Upper casing 682-45111-15-4D	Manifold 6B4-41131-00-CA	Seal damper plate 682-45126-01-CA

Seal plate 682-45127-00	Lower unit assy 6B4-45300-01-4DS 6B4-45300-10-4DL	Pinion gear bearing 93315-314V8	Drive shaft 6B4-45501-00 6B4-45501-10	Cooling water hose 682-44361-01 682-44361-11
Water pump housing 682-44300-40	Insert cartridge 682-44322-41	Impeller 682-44352-03	Cartridge outer plate 682-44323-40	Water pump below base 6E7-45331-00-CA
Clutch dog 682-45631-00	Pinion gear 63V-45551-00	Gear I 6E7-45560-01	Gear II 6E7-45571-00	Propeller shaft 683-45611-00
Lower casing cap 683-45361-02-4D	Propeller assy 683-45941-00	Lower casing anode 6B4-45251-00	Bracket lter 648-24566-02	Shift bracket 6B4-41662-00
Handle transom clamp 6E0-43118-01	Fuel line assy 61J-24306-03	Fuel tank assy 6YJ-24201-00		

T30 OUTBOARD SPARE PARTS



Crankshaft
69P-11400-00



Carburetor
61N-14301-00



Upper front mount
damper
689-45516-00



Pull rod shaft
90249-06M22



Handle collar
90387-13003



Handle bush
90387-33001

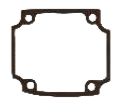

Exhaust manifold
gasket
69P-41134-A0



Shift rod bracket
69P-44518-00-94



Inner frame pull rod
648-43617-00



Pull rod bracket
648-43642-00



Mount damper gasket
648-44591-A0



Absorber assy
664-44514-00-94



Exhaust gasket A1
69P-45127-00



Exhaust gasket A2
69P-45128-00



Clamp lever
689-42815-00



Bushing
664-42715-00



Shift cam plunger
664-44167-01



Clamp bracket
689-43112-02-4D
689-43111-03-4D



Pull rod
689-43616-00



Locking handle
689-43631-00



Tilt lever cover
689-43633-00



Wrest spring
689-43643-00



Compression spring
90501-14M07



Impeller
6H4-44352-02



Water inlet A
6L2-45214-00



Water inlet B
6L2-45215-00



Bracket
61N-44176-00



Lower casing 61N-45311-02-4D	Drive shaft base 61N-45331-00-5B	Lower casing cap 61N-45361-01-4D	Course tab 61N-45371-00	Pinion gear 61N-45551-00
---------------------------------	-------------------------------------	-------------------------------------	----------------------------	-----------------------------



Exhaust outer cover 61N-41123-00-1S	Cylinder head cover gasket 61T-11193-A1	Thermostat gasket 655-12414-A1	Engine gasket 689-45113-A1	Spark plug 94702-00217
--	---	-----------------------------------	-------------------------------	---------------------------



Forward gear 61N-45560-10	Reverse gear 61N-45571-00	Clutch ring 648-45633-00	Shift rod plunger 648-45635-00	Dog clutch 664-45631-02
------------------------------	------------------------------	-----------------------------	-----------------------------------	----------------------------



Fuel filter assy 61N-24560-00	Swing shaft pulley 62Y-42171-00	Valve seat gasket 648-13621-A1	Mainfold gasket 648-13645-A0	Top cowling assy 69S-42610-40-4D
----------------------------------	------------------------------------	-----------------------------------	---------------------------------	-------------------------------------



Clutch pin 90250-05010	Clutch spring 90501-10065	Drive shaft oil seal 93101-22067	O-ring A 93210-64ME7	Ball bearing 93306-00612
---------------------------	------------------------------	-------------------------------------	-------------------------	-----------------------------



Outer cover gasket 6K8-41124-A1	Throttle cable 61N-26311-00	Lower shift lever cover 61N-45321-00	Upper casing seal 69P-42716-00	Compression spring 90501-09M08
------------------------------------	--------------------------------	---	-----------------------------------	-----------------------------------



Gear I roller bearing 93332-00005	Propeller spacer 6L2-45987-02	Ignition coil assy 61N-85570-00	Lighting coil 61N-81313-09	Power supply assy 69P-85541-09 61N-85543-09
--------------------------------------	----------------------------------	------------------------------------	-------------------------------	---



Cylinder 1 head 61N-11111-01-1S	Piston ring 61N-11603-00	Piston 61N-11631-00-95	Thermostat cover 655-12413-01-1S	Piston pin 688-11633-00
------------------------------------	-----------------------------	---------------------------	-------------------------------------	----------------------------



Piston circlip 688-11634-00	Exhaust inner cover 6K8-41121-00-1S	Exhaust inner cover gasket 6K8-41122-A1	Cylinder head gasket 61N-11181-A1	Cylinder head 1 cover 61N-11191-01-1S
--------------------------------	--	---	--------------------------------------	--



T40X
OUTBOARD
SPARE PARTS



Tilt lock inner bracket 65W-43613-00	Tilt lock inner bracket B 65W-43614-01	Tilt lock inner bracket A 65W-43615-01	Bracket link 65W-43616-00	Tilt clamp handle assy 65W-43630-11
Clamp bracket 66T-43112-01-4D 66T-43111-01-4D	Tilt lock lever 66T-43631-11	Nylon washer 90202-12031	Locking bracket L 90249-07M32	Outer bracket S 90249-07M33
Sleeve 90387-07M29	Tension spring 90506-30M00	Mount damper 65W-44555-10	Double hole absorber assy 66T-44514-00-4D	Absorber plate 66T-44526-00

Carburetor 66T-14301-02	Crankshaft 66T-11400-01	Front damper 66T-44575-00	Lock plate assy 648-42528-00	Rotary bracket bush 90386-44M03
Rotary bracket washer 90386-44M99	Rotary bracket bush 90386-52M02	O-ring 93210-43MJ0	Handle plate 65W-42131-01	Shift handle 66T-44111-02
Shift rod 66T-44124-00	Lower casing jam 63D-45155-00	Exhaust seat gasket 66T-45114-A0	Drive shaft bush 679-45318-00	Clamp lever 66T-42815-01-4D
Locked block spring 90506-16M34	Pulser coil link 66T-41237-00	Throttle drive pulley 66T-41638-00	Drive wheel spring 66T-42167-00	Shift rod lever assy 66T-44121-00



Throttle block
66T-44125-01

Shift lever spring
682-44116-01

Impeller
6H4-44352-02

Nylon bush
6H4-45536-00

Oil seal casing A
63D-44341-00

Drive shaft seal A
90480-25M70

Drive shaft seal B
90480-30M71

Charge coil
66T-85520-00

Pulser coil
66T-85596-00

Ringent washer
90480-10M71



Water inlet A
63D-45214-00

Water inlet B
63D-45215-00

Lower casing cap
63D-45361-02-4D

Outer plate
66T-44323-00

Lower casing
66T-45311-01-4D

90387-06M80
Intake silencer bush

Cylinder head
66T-11111-01-1S

Cylinder head gasket
66T-11181-A3

Cylinder head cover
66T-11191-00-1S

Cylinder cover gasket
66T-11193-A3



Oil seal cover
66T-45344-01

Pinion gear
66T-45551-00

Forward gear
66T-45560-01

Reverse gear
66T-45571-00

Dog clutch
66T-45631-00

Crankshaft xed washer
66T-11565-00

Oil seal casing
66T-15396-01-94

Exhaust cover
66T-41113-00-1S

Exhaust cover gasket
66T-41114-A0

Thermostat cover
676-12413-00-1S



Clutch ring
663-45633-00

Pinion gear nut
90170-12138

Clutch pin
90250-06023

Water pump housing
o-ring
93210-59MG7

Needle bearing
93317-22204

Oil seal
93102-30M56

Spark plug
94702-00272

Piston ring
66T-11603-00

Piston assy
66T-11631-01-93

Fuel tting assy
6G1-24304-02



Roller bearing
93332-00001

Water pump housing
cover
63D-44312-00

Water seal
63D-45375-00

Drive shaft L bush
66T-44362-10

Propeller bush A
66T-45997-00

Ignition coil assy
66T-85570-00

Top cowling assy
66T-42610-K0-4D

Engine gasket
66T-45113-A0

Fuel pump gasket
650-24431-A0

Thermostat gasket
676-12414-A1



Water tube seal
663-44366-00

Water tube bush
663-44367-00

Water seal plate
663-45376-00

Propeller bush B
90389-22M01

Water tube seal
90430-12072

Water pump base
gasket
63D-44316-00

Exhaust manifold
gasket
66T-41133-A0

Stopper shaft
65W-43191-00

Damper seal
65W-43373-00

Bush
90386-10M99



**T40J
T40G
OUTBOARD
SPARE PARTS**



Transom clamp handle
663-43118-01-4D



Steering bracket
676-42511-02-4D



Steering pivot shaft
676-42521-00-94



Swivel bracket
676-43311-10-4D



Upper side of
mount damper
679-44514-00-94



Lower side of
mount damper
679-44555-00-94



Stopper
6F5-43627-80
6F5-43628-80



Lower casing
6J4-W4531-01-4D



Steering handle shaft
676-42115-00



Exhaust pipe seat
6F5-41116-00-5B



Exhaust manifold seat
6F5-41137-02-94



Engine gasket
6F5-45113-A0



Exhaust pipe
676-41131-01-5B



Exhaust pipe gasket
676-41133-A1



Exhaust manifold
gasket
676-45114-A1



Engine stop switch assy
682-82556-00
6E9-82575-02



Locking handle
6F5-42815-01-4D



Bottom cowling
6F6-42711-02-4D



Throttle link rod
6F5-41211-00



Throttle actuator pulley
6F5-41283-00



Shift handle
6F5-44111-00



Shift cam plate
6F5-44121-00



Shift rod lever B
6F5-44125-00



Shift control lever A
6F5-44173-00



Shift rod connector
648-44146-00



Carburetor
6F5-14301-00



Impeller
6F5-44352-00



Water pump insert
cover



Shift rod boost
650-44147-00



Water seal damper
663-44366-00



Dog clutch
663-45631-01



Clutch ring
663-45633-00



Cartridge outer plate
676-44323-40



Shift cam shaft assy L
679-44150-10



Bae plate gasket
679-45315-A1



Bearing housing
679-45331-00-94



Drive shaft L
679-45501-10



Propeller shaft
679-45611-01



Crown nut
697-45384-00



Pinion gear nut
90170-12138



Pinion gear
6F5-45551-00



Forward gear
6F5-45560-00



Reverse gear
6F5-45571-00



Pinion gear
679-45551-00



Forward gear
679-45560-01



Reverse gear
679-45570-00



Clutch pin
90250-06023



Clutch spring
90501-16M01



Gear II ball bearing
93306-00702



Bearing
93315-32224
93317-22204



Drive shaft roller
bearing
93332-00001



Gear I roller bearing
93332-00003



Propeller
69W-45952-00-EL



Water seal
663-45375-00



Water seal plate
663-45376-00-94



Propeller spacer
663-45987-02



Fuel pump
692-24410-00



Intake valve gasket
6F5-13621-A1



Intake manifold 1
gasket
6F5-13645-A1



Intake manifold 2
gasket
6F5-13646-A2



Carburetor gasket
6F5-14198-A1



Water pipe L
676-44361-10



Water inlet A&B
688-45215-02
688-45214-02



Slotted nut
90171-16011



Inlet nut
90185-05002



Plug
90338-22007



Intake valve assy
6F6-13610-00



Choke linker
6F6-41256-00



Intake silencer
6F5-14417-00
6F5-14418-00



Choke handle
682-41271-00



Top cowling rubber seal
6F5-42615-00



Cotter pin
91490-30025



Ignition coil
6F6-85530-00



C.D.I unit assy
6F6-85540-10



Thermosensor
688-82560-10



Charging coil
6F5-85520-00



Starter stop cable comp
6F5-15770-00



Detent cable frame A
6F5-15773-00



Detent cable frame B
6F5-15774-00



Starter assy
6F5-W1571-02



Termostato cover
6E9-12413-00-1S



Lighting coil
6F5-85533-00



Flywheel
6F5-85550-F2



Pulser coil assy
6F5-85580-00



Flywheel nut
90170-20137



Stator coil base



Termostato cover
gasket
6E9-12414-A1



Cylinder 1 head gasket
6F5-11181-A1

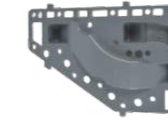

Exhaust inner cover
6F5-41111-01-1S



Exhaust outer cover
6F5-41113-01-1S



Cylinder 1 head
6F6-11111-00-1S



Crankshaft assy
6F6-11400-01



Piston assy
6F6-11631-00-95



Piston needle bearing
93603-21111



Thermostat
6F5-12411-02

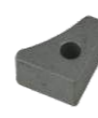

Crankcase anode B
676-11325-00



Cylinder 1 head cover
6F6-11191-00-1S



Head cover gasket
6F6-11193-A1



Crankcase assy
6F6-15100-00-1S



Handle steering assy
6F6-W0084-00-4D



Top cowling assy
6J4-42610-J0-4D



Crankcase anode A
676-45251-00



Sprak plug
94702-00272



Fuel pipe joint comp
6G1-24304-02



Fuel lter cup assy
61N-24560-00



Fuel pump gasket
650-24431-A0



Clamp bracket set
676-43111-04-4D
676-43112-04-4D



Water pump gasket
676-44315-A1



Cartridge gasket
676-44324-A1



Water pump gasket
679-44316-A1



Oil seal



PROPELLER ASSY

for YAMAHA model



2HP

7-1/4*5-A
6F8-45942-01



2.5HP

7-1/4*5-1/2
6L5-45952-00



2.5HP

7-1/4*6
6L5-45943-00



4-6HP

7-1/2*7-BA
6L5-45952-00



4-6HP

7-1/2*8-BA
6E0-45941-01



6-8HP

8-1/2*8-1/2-N
6G1-45941-00-EL



6-8HP

8-1/2*7-1/2-N
6G1-45943-00-EL



9.9-15HP

9-1/4*8-J1
63V-45947-00-EL



9.9-15HP

9-1/4*9-J1
63V-45945-10-EL



9.9-15HP

9-1/4*10-J1
63V-45952-10-EL



9.9-15HP

9-1/4*11-J1
63V-45943-10-EL



9.9-15HP

9-1/4*12-J1
63V-45941-00-EL



9.9-15HP

9-1/4*8-J
683-45947-00-EL



9.9-15HP

9-1/4*9-J
683-45945-00-EL



9.9-15HP

9-1/4*9-3/4-J
683-45952-00-EL



9.9-15HP

9-1/4*10-1/2-J
683-45943-00-EL



9.9-15HP

9-1/4*12-J
683-45941-00-EL



20-30HP

9-7/8*9-F
664-45941-01-EL



20-30HP

9-7/8*10-1/2-F
664-45945-00-EL



20-30HP

9-7/8*11-1/4-F
664-45947-01-EL



20-30HP

9-7/8*12-F
664-45954-01-EL



20-30HP

9-7/8*13-F
664-45949-02-EL



40HP

11-3/4*7-1/2-H
676-45956-61-EL



40HP

11-3/4*10-H
676-45945-62-EL



40HP

11-1/2*11-H
676-45941-62-EL



40HP

11-1/2*12-H
676-45943-62-EL



40-60HP

11-3/4*10-G
663-45954-01-EL



40-60HP

11-5/8*11-G
69W-45947-00-EL



40-60HP

11-3/8*12-G
663-45952-02-EL



40-60HP

11-1/2*13-G
663-45974-02-98



40-60HP

11-1/8*13-G
69W-45945-00-EL



40-60HP

11-1/4*14-G
663-45958-01-EL



40-60HP

11*15-G
663-45943-02-EL



50-130HP

14*11-K
6E5-45954-00-EL



50-130HP

13-5/8*13-K
6E5-45949-00-EL



50-130HP

13-1/2*15-K
6E5-45947-00-EL



50-130HP

13-1/4*17-K
6E5-45945-01-EL



50-130HP

13*19-K
6E5-45941-00-EL



50-140HP

13*17-K2
688-45930-02-98



130-300HP

13-3/4*17-M2
6G5-45978-03-98



150-300HP

13-3/4*19-M2
6G5-45974-03-98



150-300HP

14*19-M
6G5-45945-01-98

for SUZUKI model



4-6HP

7-1/2*7
58110-91JN0-019



15HP

9-1/4*8
58100-93753-019



15HP













9-1/4*9
58100-93723-019





























for **MERCURY** model

 15HP 9 -1/4*10 58100-93733-019	 15HP 9-1/4*11 58100-93743-019	 20-30HP 10-1/4*11 58100-96420-019	 20-30HP 10-1/4*12 58100-96430-019	 20-30HP 10-1/4*13 58100-96440-019
 35-65HP 11-1/2*10 58100-95212-019	 35-65HP 11-1/2*11 58100-95222-019	 35-65HP 11-5/8*12 58100-95393-019	 35-65HP 11-1/2*13 58100-94313-019	 35-65HP 11-3/8*14 58100-95353-019
 35-65HP 11-1/4*15 58100-88L62	 60-140HP 13-1/2*15 58100-94500-019	 60-140HP 13-1/4*17 58100-90J00-019	 60-140HP 14*19 58100-90J10-019	

for **TOHATSU** model

	 4-6HP 7.8*8 3R1B645161	 4-6HP 7.8*8 3RIW645160	 4-6HP 7.8*9 369B645181	
 8-9.8HP 8.5*9 3B2B645170	 9.9-18HP 9.25*9 362B641010	 9.9-18HP 9.7*10 3R0B645210	 9.9-18HP 9.25*10.5 3BAB645241	 25-30HP 9.9*11 3R0B645230
 25-30HP 9.9*13 3R0B645270	 35-50HP 11.6*11 3T5B645230	 35-50HP 11.4*12 3T5B645250	 35-50HP 11.1*13 3T5B645270	 35-50HP 11.1*13 3T5B645271

 4-6HP 7.8*8 48-812950A02	 5HP 7.8*9 48-812951A02	 8-9.8HP 8.9*8.5 48-897618A10		
 8-9.8HP 8.5*9 48-897618A10	 6-15HP 9*8 48-828154A12	 6-15HP 9*9 48-828156A12	 6-15HP 9*10-1/2 48-828158A12	 9.9-20HP 9.25*9 48-897750A11
 9.9-20HP 9.25*10 48-897752A11	 9.9-20HP 9.25*11 48-897754A11	 25-30HP 9.9*13 48-19640A40	 9.9-25HP 10-3/8*11 48-19638A40	 9.9-25HP 10-3/8*12 48-19639A40
 9.9-25HP 10-3/8*13 48-19640A40	 40HP 10-7/8*11 48-85632A45	 40HP 10-3/4*12 48-816702A45	 40HP 10-5/8*12 48-73134A45	 40HP 10-1/2*13 48-816704A45
 40HP 10-3/8*13 48-73136A45	 40HP 10-3/8*14 48-816706A45	 40HP 10-1/4*14 48-73138A45	 40HP 11-5/8*11 48-823478A5	 40HP 11-3/8*12 48-855856A5
 40HP 11-1/8*13 48-855860A	 60HP 13-1/4*17 48-77344A45	 60HP 14-1/2*19 48-832830A45		